

Flow-through Cell High Flow Setup

Manning samplers are designed for use with non-pressurized fluid sources. In some instances, it is necessary to sample from a pressurized pipe or other source. The Flow-through Cell (FTC) High Flow Setup allows sampling from pressurized sources by relieving the pressure. The FTC operates by opening the stream to the atmosphere, thereby reducing the effective pressure to zero.

Operation

The pressurized source is connected to the ball valve on the inlet of the FTC (refer to Drawing on reverse side). NOTE: Maximum pressure for the FTC is 150 psi. If the optional electrically actuated (EA) ball valve is used, the FTC can be installed with the EA ball valve adjacent to the manual ball valve or at some other location between the manual ball valve and the source fluid. The ball valve is used to adjust the flow to ensure that no fluid will exit the sampler intake if open to air. It also allows fluid to the FTC to be shut off for cleaning and maintenance.

Fluid enters the clear PVC wye and flows out of the FTC to an open-air drain. It is important there are no restrictions after the wye. The third opening on the clear PVC wye is attached to the sampler intake hose using a bushing and fittings. An intake tube attached to the bushing

allows the sampler to draw fluid from and purge fluid back to the FTC. The bushing can be easily removed for cleaning.

General Installation

The source fluid must be piped to the FTC and a drain open to the atmosphere must be available for fluid that has passed through the FTC. The sampler must be located higher than the FTC, and the intake line to the sampler must be routed so there are no dips where fluid can collect.

It is important that the pipe from the FTC outlet to the drain has no reductions. Any reductions or excessive elbows will increase the pressure at the intake point for the sampler. The FTC is designed to allow the flow to be restricted by the manual valve. This can reduce the overall fluid that must be sent to the drain. It also allows the pressure to be reduced by reducing the incoming fluid. If high solids are present, consideration must be made for clogging. In instances where the flow cannot be reduced sufficiently with the manual ball valve, an additional pressure reduction means must be installed before the FTC.

Normally, flow through the FTC is continuous. In some applications, it is desirable to only have flow

through the FTC during a sample cycle. To accomplish this, an electrically actuated ball valve may be installed close to the pressurized source. (A 3/4" or 1-1/2" valve may be used, depending on the application. Use the appropriate pipe and pipe reducers to connect the 1-1/2" wye.) This valve is opened only during the sample cycle.

Most electrically actuated ball valves require a relay to control them. This relay and the sampler can be controlled by a PLC or other control circuitry. If the Alarm Option is installed on the sampler, the SAMPLE CYCLE relay can be used to control the ball valve relay.

The FTC may be mounted close to the pressurized source with an intake hose connecting it to the sampler. Depending upon the application, the FTC may require additional mounting support (customer-supplied).

Manning flow-through cell high flow setups are available for 5/8-inch ID intake hose in non-toxic applications:

Part Number	Description
MS889632	Flow-through Cell High Flow Setup, 5/8-inch Intake
MS889633	Flow-through Cell High Flow Setup, 3/8-inch Intake

Headquarters and Sales:

Manning Environmental, Inc.
 1968 South Austin Avenue
 Suite 101
 Georgetown, Texas 78626

Phone: (800) 863-9337
 Fax: (512) 863-4472
 Email: sales@manning-enviro.com
 Web: www.manning-enviro.com

In the interest of improving and updating its equipment, Manning reserves the right to alter specifications to equipment at any time.

HIGH FLOW SETUP

OPTIONAL 3/4"
MOTORIZED BALL VALVE
CONTROLLED BY SAMPLER

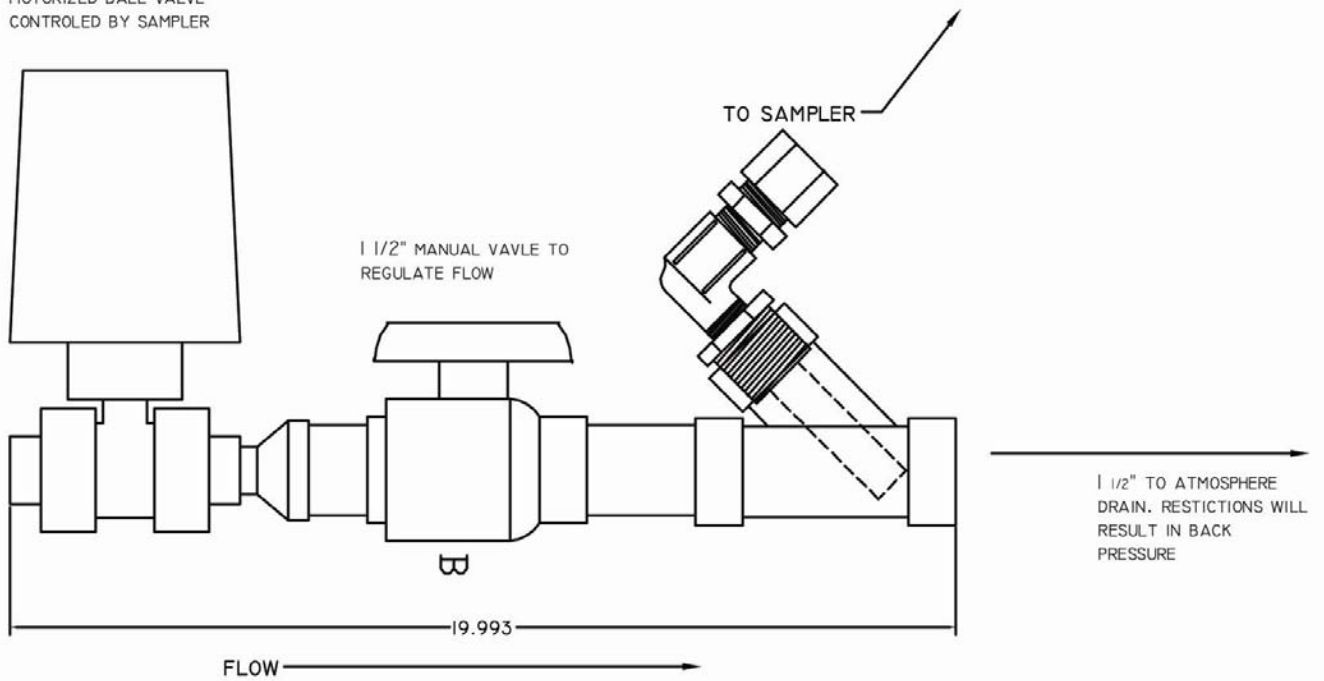

Flow-through Cell High Flow Setup